

DISCLAIMER

I will not accept any responsibility or liability for any damages
by inappropriate handling of the product.

Please read the instructions before use. Follow the tips.

Important

Please don't remove the "ZINSTAX" sticker on the top cover.

It's there to cover the original FUJIFILM logo to avoid trademark infringement. Thanks!

Scan for a quick start guide



or go to zins.tax/support

Check out hundreds of story highlights around **zinstax**
on my Instagram page!

Feel free to tag me and join the community :)

 [@haan.chen](https://www.instagram.com/haan.chen)

 hello@zins.tax

Thanks for purchasing **zinstax**! Here's how to use it:

1. Use Fujifilm Instax Square film (I get asked a lot). It's an ISO 800 film. Polaroid films or your favorite chocolate-chip cookies won't fit.
2. No battery needed, your **zinstax** is fully mechanical.
3. The hook in the bottom right corner in the film compartment should be lowered to the bottom every time before you pop in a new pack of film. It will be in the right place after each film ejection; if not, move it down by turning the crank counterclockwise continuously. Otherwise, the ejection unit may not work properly.
4. Set the R-M lever on the RZ67 body to the "M" position.
5. Align the pink dot on **zinstax** with the orange dot on the RZ67 body to mount. Press **zinstax** against the RZ67 body to help the locking ring line up with the groove in the pins. Turn the locking lever to secure **zinstax** in place.
6. If the film ejection slot is not facing upwards, rotate **zinstax** clockwise. You can absolutely shoot it sideways if you prefer. I'd recommend not using **zinstax** with a prism finder as it blocks either the film ejection slot or the crank, but hey, nothing stops you from doing that.
7. Pull out the dark slide and place it in the dark slide holder.
8. Shoot and crank counterclockwise to eject. The film counter should go down by one.

Here are some tips:

1. Always turn the crank counterclockwise (in direction of the white arrow on the crank). Otherwise, the ejection unit can be damaged. Crank slowly, gently, and steadily. Secure the crank with tape before tossing it in the bag.
2. **zinstax** doesn't have a locking mechanism to prevent the locking ring from coming loose by itself, so make sure the locking lever is in the locked position during your shoot.
3. Insert the dark slide straight into the body, not at an angle. You will feel more resistance than you're used to with 120 film backs, and it's normal. The dark slide could be stuck at arrow-pointed areas. If it feels stuck, wiggle it up and down while inserting or flip it and try again.

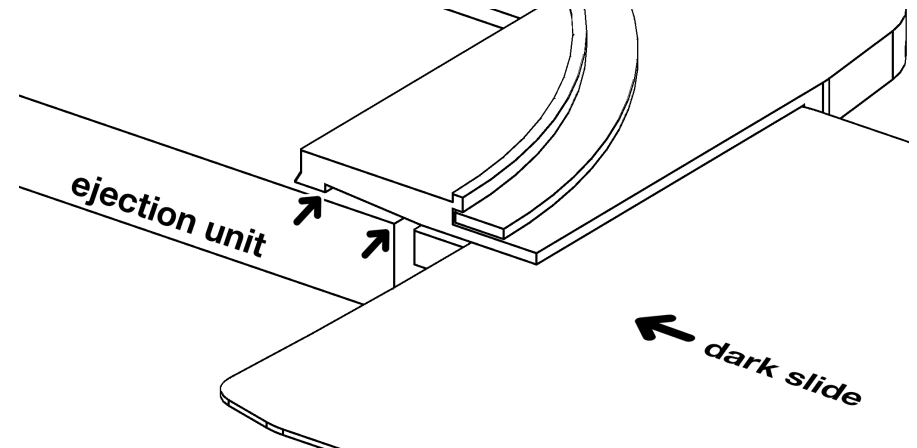

4. By design, the back activates both horizontal and vertical in-body masks, so what you see in the viewfinder is (approx.) what you get.
5. If you see a vertical line of white dots on the film, clean the rollers. To do that, open the film door and turn the crank slowly. Alternatively, you can blow the dirt off with compressed air.